



A REVIEW PAPER ON CORDIC ALGORITHM AND ITS APPLICATIONS FOR CURRENT TECHNOLOGY

Praveen Yadav, Karan Singh

Chouksey Engineering College, Bilaspur

Article history:

Submitted on: May 2016

Accepted on: June 2016

Email: info@jusres.com

ABSTRACT:

CORDIC (Coordinate Rotation Digital Computer), also known as the digit-by-digit method and Volder's algorithm. This is a special-purpose digital computer for real-time airborne computation. In this, a unique computing technique is employed which is especially suitable for solving the trigonometric relationships involved in plane coordinate rotation and conversion from rectangular to polar coordinates. CORDIC algorithm is also applicable for square root, Logarithmic, Exponential function and for digital computer. In computation unit trigonometric functions are very crucial; at present many mathematical function require Sine, Cosine, Tangent etc, and by using this algorithm it easy to compute. With ongoing technology and limitations on power, operating frequency and energy consumption, if we are generating any trigonometry functions by using of multiplier, adder, divider those architectures consumes more hardware and computational time in- creases, for reduction of this problem CORDIC algorithm is converted into hardware form which is known as CORDIC processor. In this paper basically we did a comparative study between the existing CORDIC algorithms. In present era CORDIC algorithm is used in many applications like Multimedia, Digital Signal Processing applications like Smooth Filters, DCT, and FFT etc.

KEY INDEX: CORDIC, Algorithm, FLOW, Communication, Latency.

INTRODUCTION

CORDIC (Coordinate Rotation Digital Computer), also known as the digit-by-digit method and Volder's algorithm. This is a special-purpose digital computer for real-time airborne computation. In this, a unique computing technique is employed which is especially suitable for solving the trigonometric relationships involved in plane coordinate rotation and conversion from rectangular to polar coordinates.

CORDIC algorithm is also applicable for square root, Logarithmic, Exponential function and for digital computer. In computation unit trigonometric functions are very crucial; at present many mathematical function require Sine, Cosine, Tangent etc, and by using this algorithm it easy to compute. With ongoing technology and limitations on power, operating frequency and energy consumption, if we are generating any trigonometry functions by using of multiplier, adder, divider, those architectures consumes more hardware and computational time in-creases, for reduction of this problem CORDIC algorithm is converted into hardware form which is known as CORDIC processor. This processor reduces the problem of division and multiplication.

In CORDIC processor we can compute the functions by using of shifter, adder and subtractor. In present era CORDIC algorithm is used in many applications like Multimedia, Digital Signal Processing. First CORDIC algorithm [1] is converted into hardware so it was facing some problems like scale factor, time consuming etc. In CORDIC algorithm many modification is done but still it facing many problems so as for future scope this CORDIC processor require many modification.

As we know is present era every multimedia and aerospace based application is require fast processing unit. We also know if any system is complete based on General purpose processor so efficiency of the complete system will be reduce. For application specification there is need of dedicated application specific processor. So here for the aerospace and multimedia application which is based on trigonometric function. So for those kind of application there is need of specific process which is known as CORDIC processor.

1.1 APPLICATIONS:

CORDIC uses simple shift-add operations for several computing tasks such as the calculation of trigonometric, hyperbolic and logarithmic functions, real and complex multiplications, division, square-root calculation, solution of linear systems, eigenvalue estimation, singular value decomposition, QR factorization and many others. As a consequence, CORDIC has been used for applications in diverse areas such as:

1. **Signal and image processing[20]**

2. **Communication & Wireless Technology [21]**
3. **Robotics and 3D graphics**
4. **Aerospace Application.**
5. **Discrete Cosine Transform (Image Compression Unit).**
6. **Different DSP and DIP Filters.**
7. **Network Security [22]**
8. **Biometric [23]**
9. **Fuzzy Logic based Control System [24]**
10. **Multimedia Applications**

If we are talking about the working of CORDIC algorithm on those applications, so its followings:

1.1.1 SIGNAL & IMAGE PROCESSING: Image data which is processed for communication mainly undergo with some standards of Digital Image Processing (DIP) compression like JPEG (Joint Photographic Expert Group), MPEG-x (Motion Picture Expert Group), which begins major component in today's data centered world. Image and video procession governs mainly with the processing unit mainly known as compression unit. Compression unit is distinguished on two types: Lossless: In this the image pixels are not compressed or compromised. Lossy: With the help of some transform, utmost compression is achieved. Here **DCT** is applications which need cosine signal so on that application we can apply CORDIC algorithm. Similar **DWT, Gabour file** need this algorithm.

1.1.2 DISCRETE COSINE TRANSFORM (IMAGE COMPRESSION UNIT): Like other transforms, the Discrete Cosine Transform (DCT) attempts to de-correlate the image data. After decorrelation each transform coefficient can be encoded independently without losing compression efficiency. This section describes the DCT and some of its important properties. Using CORDIC algorithm we find the transformation.

1.1.3 MULTIMEDIA APPLICATION

In present era, multimedia has become an integrated part of every communication and contains data like message, images, videos, as source of information. This information constitutes a large flow of data into network & thus affects the channel bandwidth with more power requirement for hand-held devices. This limits the multimedia application to become user friendly, but in-fact most of applications mainly deals with image and video data, because human are more attracted towards visual (image/video) data. CORDIC algorithm act a very important role for these applications.

1.1.4 AEROSPACE APPLICATION: his application need CORDIC algorithm because in this application we have to find the motion of the aerospace and that is possible by the calculation some trigonometric functions.

1.1.5 COMMUNICATION SYSTEM: This system also need the CORDIC algorithm because in this application we have to calculate multiple trigonometric function which are use in the transformation of 3G and \$g network

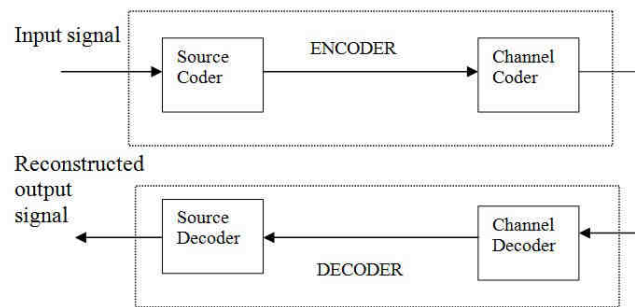

Fig. 1.1.1 Communication System

This paper is device in five sections where, second one is literature review, third one is previous research issues, fourth one is future scope of CORDIC algorithm and last one is conclusion which conclude the whole paper.

2. LITERATURE REVIEW

First CORDIC algorithm is developed in 1959 in this the author proposed solution for trigonometric function and rotation, but this approach is facing with many problem like heavy hardware is require, constant term and scale factor is also a major problem [1]. An-other new approach is developed [2], in this paper author discuss some new factions like log, exponential and square root but this approach is also facing the same major problems scale factor, large hardware, constant term.

After the above methods a lot of improvement is done in CORDIC algorithm and many generalized technique are proposed for computing various functions like sine/cosine [3], [4], transforms [5], [6], exponents/logarithms, square roots, Eigen values [7] etc. During the past 50 years [8], there have been major advances in the design of the algorithm to overcome its major drawbacks. In [9], [10], [11] authors suggest the use of greedy search algorithms for identifying the micro-rotations.

The efficiency of these approaches are based on the probability of rotation angle which is the main problem. Implementation of it in terms of hardware is difficult and it is facing another

major problem; variable scale factor. This factor is which reduces the advantage of latency. For reduction of scale factor problem low complexity technique is used and the approach is Taylor series expansion which also has some draw backs. Range of convergence is a major problem, for Reduction of this problem some new approach is suggested. The low complexity technique for eliminating the scale factor is the use of Taylor series expansion. The Scaling-Free CORDIC and modified scale-free CORDIC [12, 13] are techniques based on Taylor series approach. The former suffers from low range of convergence (RoC) which renders it unsuitable for practical applications, while the latter extends the RoC but them facing problem of constant scale-factor of $1/\sqrt{2}$.

The Scaling-Free CORDIC and modified scale-free CORDIC [14, 15] in [14] author suggested new approach for generation of sine/cosine, in this approach author eliminate a ROM and a large barrel shifter in the hardware implementation of the CORDIC system, but this approach suffers from low range of convergence (RoC) which render sit unsuitable for practical applications, in [15] author proposed one new technique for reduction of scale factor and number of iterations. They focused on Radix-4 Modified Booth Recording- Modification of CORDIC algorithm is Radix-4 modified booth recording, with this it keeps working without a scale factor and the corresponding hardware for data path can still be excluded, while enabling each iteration in pipeline stage which process two bits at a time from the vector. By this author achieve reduction in number of iterations. Constant multiplier- there is one constant term is produce which is $1/\sqrt{2}$ for this constant term in previous works extra hardware is require, so this can be avoided by constant multiplier which is reduce extra hardware problem. Domain Folding Elimination, in previous work angle of the scaling-free

CORDIC kernel is between $0 \frac{\pi}{2} \frac{\pi}{2}$ to $\frac{\pi}{8}$ rad but in this work convergence range is between – to, [14, 15] also facing constant scale factor problem. In [18] here author propose the leading-one bit detection technique to identify the micro-rotations. The scale free design of the proposed algorithm is based on Taylor series expansion of the sine and cosine waves. In [19] author use the same approach but there they implement Hyperbolic CORDIC function.

2.1 BASIC CORDIC ALGORITHM:

CORDIC ALGORITHM [1] The underlying principle of the CORDIC algorithm is based on two-dimension geometry. This algorithm operates either in or rotation or vectoring mode, following linear, circular or hyperbolic trajectories. We focus on rotation mode of operation in circular trajectory.

A. Conventional CORDIC Algorithm Let the vector $V_a [X_a, Y_b]$ be derived by rotating the vector $V_b [X_a Y_b]$ through an angle θ , then:

$$\begin{bmatrix} X_b \\ Y_b \end{bmatrix} = R_p \cdot \begin{bmatrix} X_a \\ Y_a \end{bmatrix}, R_p = \begin{bmatrix} \cos\theta & -\sin\theta \\ \sin\theta & \cos\theta \end{bmatrix} \quad (1)$$

Equation (1) forms the basic principle for iterative coordinate calculation in CORDIC algorithm [1]. The key concept in realizing rotations using CORDIC is to express the angle of rotation θ as an aggregation of pre-defined elementary angles defined as: where b is the word-length in bits. (2)

$$\theta = \sum_{i=0}^B u_i * a_i \quad (2)$$

Where $u_i = -1, 1; a_i = \tan^{-1} 2^{-i}$

The RoC of the conventional CORDIC is $[-99.9 \text{ deg}, 99.9 \text{ deg}]$ and using extra iteration step can be extended to the entire coordinate space. The rotation matrix R_p , in its original form is computation intensive; it requires computing sine and cosine functions with four multiplication and two addition operations. Factoring the cosine term simplifies the rotation matrix R_p (1) by converting the multiplication to shift operations, as tangent of the elementary angles is defined in negative powers of two(2). But the penalty paid is the introduction of the scale-factor which varies according to the cosine of the elementary-rotation.

COSINE waves based on the CORDIC (Coordinate Rotation Digital Computer) algorithm. [16].this suggested an novel approach in this approach author uses leading-one bit detection technique to identify the micro-rotations. This process eliminate complex search algorithm. The scale free design of the algorithm is based on Taylor series expansion of the sine and cosine waves. This proposed algorithm is up to fourth order of Taylor series. Micro-Rotation Sequence Generation, in previous work for angle rotation ROM is required but by using of Micro Rotation Sequence Generation no any ROM require for storing the elementary angles of rotation. this proposed algorithm is also facing with many problems like increase in error; number of iteration increases, to reduce this problem another approach is suggested [17]. In this approach author using same technique of [16]but they convert that architecture in to parallel form they proposed CORDIC parallel rotator implementation to be maximally optimized for high performance with the lower cost in area-consuming.

direction of micro-rotation. With sequential execution of large number of iterations it tends to a constant, referred to as the gain of the CORDIC algorithm. The scale-factor is thus compensated either in the post or pre processing unit.

$$Rp = Ki. \begin{bmatrix} 1 & -ui. 2^{-i}\Theta \\ ui. 2^{-i} & Cos\Theta 1 \end{bmatrix} \quad (3)$$

B. SCALE FREE REVIEW:

Scaling-free CORDIC [12] was the first attempt to design scale-free coordinate CORDIC equations using Taylor series expansion. Here, the micro-rotations are restricted to anticlockwise direction only, such that, any angle of rotation is represented as the algebraic sum of elementary angles. The sine and cosine functions are approximated to:

$$\text{Sinai} = 2^{-i}, \text{Cosai} = 1 - 2^{2i+1} \quad (4)$$

3. PROBLEMS IN PREVIOUS RESEARCH

According to previous research there is lots of issues are there on CORDIC algorithm and CORDIC processor. Those issues are such as **Scale Factor** Many algorithms are facing from Scaling factor problem and which was addressed by many researchers in return the latency has been neglected in the improved approach. **Heavy hardware** Many algorithms require multiplier factor some are require constant multiplier factor some require number of shifter logic and heavily adder and subtractor. **Latency** [17] This approach reduces latency problem but still we can reduce latency in term of hardware. These issues can still resolve and these are most important issues which have to resolve in future because right now we are in the age of HD vision and 4G communication technology where we need fast algorithms.

4. FUTURE SCOPE ON CORDIC ALGORITHM

CORDIC algorithm is useful in many application like Digital Signal Processing, Multimedia, Function Generation but still CORDIC processor faces many problems which I discussed in research gap. So there are followings object is which will resolve in future:

1. **reduction in hardware complexity**
2. **reduce scale factor problem**
3. **Reduction in Latency.**
4. **Accuracy issues**

So this is the future scope of this CORDIC algorithm which will give a new direction to the researchers.

5. CONCLUSION

According to current technology future is totally based on virtual world. Right now every thing is based on online like shopping, movies, images, educations etc. So for these type of application there is need of some other supportive system which are known as communitarian system, networking, Internet of things etc. now all these system is based on some mathematical functions which are well known as trigonometric function. Now trigonometric function is calculated by using of a interesting algorithm which is known as CORDIC algorithm. So in this paper basically we discuss about the previous existing technology and changes of technology by using of CORDIC algorithm. We also discuss the issues which is faces by CORDIC algorithm. CORDIC algorithm have lots of future scope. This algorithm will change the level of the application efficiency.

REFERENCES

1. J. E. Volder, The CORDIC Trigonometric Computing Technique, IRE Trans. Electronic Computing, Vol. EC-8, Sept 1959, pp. 330- 334.
2. J. S. Walther, A unified algorithm for elementary functions, Spring Joint Computer Conf., 1971, Proc., pp. 379385.
3. S. F. Hsiao, Y. H. Hu and T. B. Juang, A Memory Efficient and High SpeedSine/Cosine Generator Based on Parallel CORDIC Rotations, IEEE Signal Processing Letters, Vol. 11, No.2, Feb-2004, pp. 152-155
4. N. Takagi, T. Asada, and S. Yajima, Redundant CORDIC methods with a constant scale factor for sine and cosine computation, IEEE Trans. Computers, vol. 40, pp.989995, Sept. 1991.
5. K. Maharatna and S. Banerjee, A VLSI array architecture for hough transform, Pattern Recognit., vol. 34, pp. 15031512, 2001.
6. K. Maharatna, A. S. Dhar, and S. Banerjee, A VLSI array architecture for realization of DFT, DHT, DCT and DST, Signal Process., vol. 81, pp. 18131822,2001.
7. Y. H. Hu and H. M. Chern, VLSI CORDIC array structure implementation of Toeplitzeigen system solvers, in Proc. IEEE Int. Conf. Acoust. Speech, Signal Processing, NM, 1990, pp. 15751578.
8. Pramod K. Meher, Javier Walls, Tso-Bing Juang, K. Sridharan, Koushik Maharatna, 50 Years of CORDIC: Algorithms, Architectures and Applications, IEEE Transactions on Circuits and Systems I: Regular

- Papers, Vol. 56, No. 9, Sept.2009, pp. 1893- 1907.
9. C. S. Wu and A. Y. Wu, Modified vector rotational CORDIC (MVR-CORDIC)algorithm and architecture, IEEE Trans. Circuits Syst. II, vol. 48, pp. 548561, June, 2001
 10. Cheng-Shing Wu, An-Yeu Wu and Chih-Hsiu Lin, A High-Performance/Low-Latency Vector Rotational CORDIC Architecture Based on Extended Elementary Angle Set and Trellis-Based Searching Schemes, IEEE Transactions on Circuits and Systems II : Analog and Digital Signal Processing, Vol. 50, pg. 589601, No. 9, Sept. 2003.
 11. Y. H. Hu and S. Naganathan, An angle recoding method for CORDIC algorithm implementation, IEEE Trans. Computers, vol. 42, pp. 99–102, Jan. 1993.
 12. K. Maharatna, S. Banerjee, E. Grass, M. Krstic, and A. Troya, Modified virtually scaling-free adaptive CORDIC rotator algorithm and architecture, IEEE Trans. Circuits Syst. Video Technol., vol. 11, no. 11, pp. 14631474, Nov. 2005.
 13. K. Maharatna, A. Troya, S. Banerjee, and E. Grass, Virtually scaling free adaptive CORDIC rotator, IEE Proc. Comp. Dig. Tech., vol. 151, no. 6, pp. 448456, Nov.2004.
 14. Leena Vachhani, K. Sridharan and Pramod K. Meher, Efficient CORDIC Algorithms and Architectures for Low Area and High Throughput Implementation, IEEE Transactions on Circuit and Systems II: Express Briefs, Vol. 56, No. 1, pg.61-65., January 2009.
 15. F.J. Jaime, M. A. Sanchez, J. Hormigo, J. Villalba and E. L. Zapata, "Enhanced scaling-free CORDIC ," IEEE Trans. Circuits and Systems I: Regular Papers, Vol.57 No.7, pp. 1654-1662. July 2010.
 16. Aggarwal, S.; Meher, P.K.; Khare, K., "Area-Time Efficient Scaling-Free CORDIC Using Generalized Micro-Rotation Selection," Very Large Scale Integration (VLSI) Systems, IEEE Transactions on, vol.20, no.8, pp.1542, 1546, Aug. 2012
doi:10.1109/TVLSI.2011.2158459
 17. Causo, M.; Ting An; Alves de Barros Naviner, L., "Parallel scaling-free and area-time efficient CORDIC algorithm," Electronics, Circuits and Systems (ICECS),2012 19th IEEE International Conference on , vol., no., pp.149,152, 9-12 Dec.2012 doi: 10.1109/ICECS.2012.6463778
 18. Aggarwal, S.; Khare, K., "Hardware Efficient Architecture for Generating Sine/Cosine Waves," *VLSI Design*

- (VLSID), 2012 25th International Conference on, vol.,no.,pp.57,61,7-11Jan.2012
19. Aggarwal, S.; Meher, P.K.; Khare, K., "Scale-Free Hyperbolic CORDIC Processor and Its Application to Waveform Generation," *Circuits and Systems I: Regular Papers, IEEE Transactions on* , vol.60, no.2, pp.314,326, Feb.2013
20. Pravin Yadav “Watermark Implementation & Application” Akriti 2011, Rajnanadgaon.
21. Pravin Yadav “Electronic Wireless Technology Beyond 3G” Aicon 2011, Durg C.G.
22. Pravin Yadav “Network Security” Aicon 2011, Durg, C.G.
23. Pravin Yadav “Network Security using Biometric Applications” Akriti 2011, Rajnanadgaon.
24. Pravin Yadav “Fuzzy system for control applications” AICTE sponsored national Seminar on Modern trends in applied mathematics towards the application on fuzzy logic, 2010, Durg.
-